

INO-ABC 100 14-TRAY (GN2/1) COLD BANQUET TROLLEY

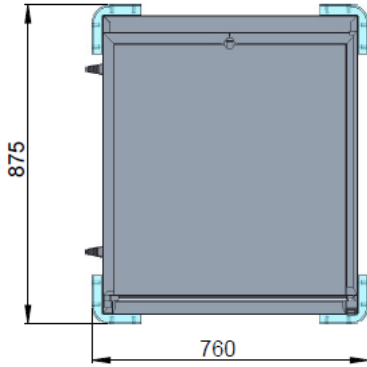
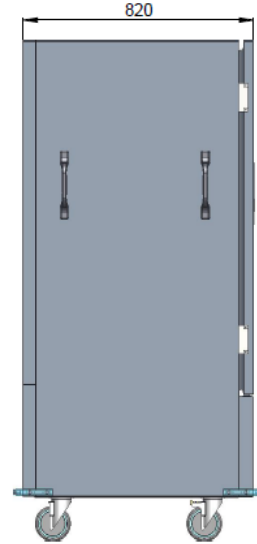
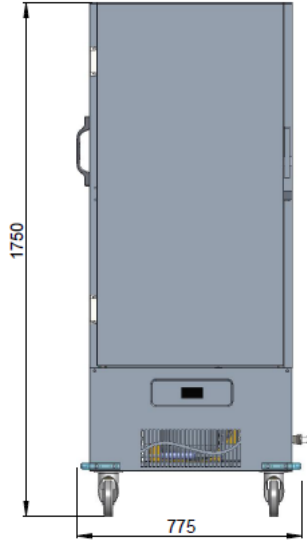

GENERAL FEATURES

- 14 units with GN2/1*40 mm cap,
- Cooling in the 0/+8°C temperature range,
- Cooling volume 440 litres, cooling gas R290,
- Body with 60 mm thick 'HCFC Free' polyurethane insulation (45 Kg/m³ density),
- Dual sensor digital thermostat,
- Fan-assisted evaporator cooling system,
- Fan-cooled and grille-ventilated motor block (compressor-condenser) group,
- Condenser cleaning warning, high/low temperature alarm, HACCP compliance, food protection feature,
- Anti-icing electric resistance defrost,
- Magnetic and removable door seals,
- Door locking system,
- Visible and product-contact surfaces made of AISI 304 quality stainless steel sheet,
- Sufficiently long corded cable for use by plugging into any desired outlet,
- Two with brakes, two without brakes, 360-degree swivel wheels
- Four rubber corner bumpers for impact absorption,

TECHNICAL SPECIFICATIONS

CAPACITY	440 Lt
GAS	R 290 100 GR CLASS T
TOTAL POWER	0,33 kW
USE	14 ADET GN2/1 TRAY
ENERGY TYPE	ELECTRIC
OPERATING VOLTAGE	230V AC 50-60 Hz